

# GTMax-S *Connect*



Find out more about  
our products & features  
on **our website**

[www.picanol.be](http://www.picanol.be)



SCAN HERE  
TO GO TO  
OUR WEBSITE

# Our design principles: how we build our machines.

When starting the design of a new machine, we have to do better than just a few picks faster than the previous generation. Today's world is all about connectivity, user-centric design, intuitive controls, self-learning capacities and sustainability ... to name just a few.

**These are the benchmarks for a future-proof design.**



## Smart Performance

Performance is the first requirement for any machine or feature, and the obvious indicator is the **theoretical maximum speed**. Very often, however, the gap between this theoretical speed and **the effective speed** under real-life conditions is huge.



## Sustainability Inside

When it comes to **preventing waste** and **reducing energy consumption**, Picanol has long faced up to its responsibility. Our machines are designed with a built-in capacity for sustainability.



## Driven by Data

We all know that **digitization** will become ever more important in the next decades. **Data** have to be captured and made available for **artificial intelligence**, making production more efficient.



## Intuitive Control

Kids nowadays handle new technology **effortlessly and intuitively**. That's what we want for our machines as well. Just like your smartphone or your car, the **machine display** is the interface that controls nearly all the machine functions.

# GTMax-S Connect



- Usable widths: 190 – 220 – 230 – 250 – 320 – 340 – 360 – 380 cm
- Up to 12 colors or yarn types (filling presenter with insertion positioning)
- BlueBox electronic platform
- Interactive touch screen with color display
- Redesigned SUMO main motor with direct machine drive with OptiSpeed
- Automatic full pickfinding and closed shed positioning
- Stäubli Dobby S2658B with Stäubli undermotion, or Jacquard with CAN communication
- Harness drive DRC2 for T-190 – T-250
- Independently electronically controlled selvage formation (ELSY)
- Electronically controlled take-up system (ETU)
- Load-cell electronically controlled warp let-off system (ELO)
- Warp beam diameter 805 mm or 1,000 mm
- Quick connection cloth roll support
- Quick connection warp beam bearing
- Push buttons on front panel with integrated signal lights
- LED signal torch with integrated temperature and humidity sensor
- Available in dedicated silk execution with optional EcoFill
- PicConnect enabled

# Built in the factory of **the future**



For more than eighty years, Picanol has played a pioneering role in the global industry and is currently one of the world’s leading weaving machine manufacturers. Picanol develops, manufactures and sells high-tech weaving machines based on airjet and rapier technology and offers digital services for its weaving machines, as well as weaving frames and reeds, upgrade kits, spare parts, training and troubleshooting services. Picanol is part of Picanol Group, a business unit of Tessenderlo Group (Euronext: TESB). For more information, go to [www.picanol.be](http://www.picanol.be)

## GTMax-S **Connect** Technical specifications

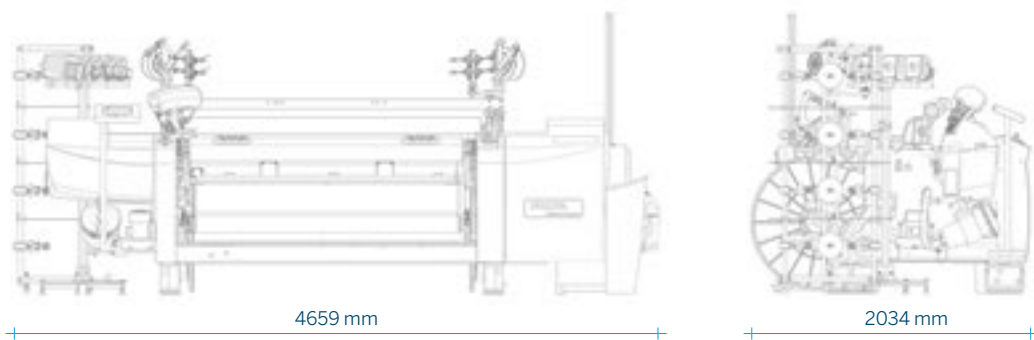

RCB0020 – 4 – R – 190 → Reed width  
 ↳ Shedding motion  
 ↳ Number of filling colors

The illustrations and descriptions in this publication do not commit Picanol in any way: specifications may change as a result of developments in engineering and materials. EN 03.01.2023.



Steverlyncklaan 15, 8900 Ieper, Belgium  
 +32 57 222 111 - info@picanol.be

